

Question 4

- (a) Fig Q4a shows the layout of an engine control unit of a simple aircraft, with the pilot inside the engine control loop. Modify this figure to show how you would upgrade the engine control unit into a full authority control system, driven by-wire. Explain your drawing. (8 marks)

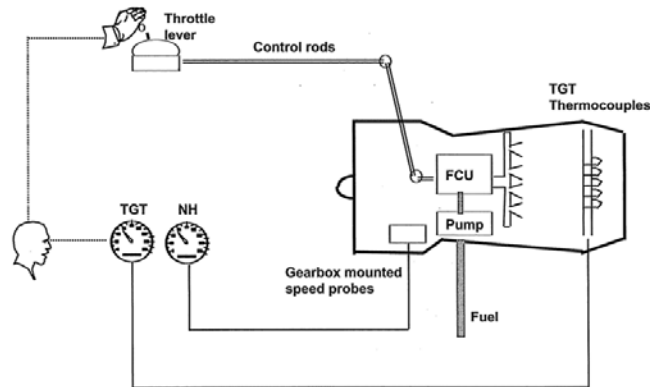

Fig. Q4a

- (b) Fig. Q4b shows the simplified fuel storage system of a commercial jetliner. The flow of fuel is managed by a fuel management system. Give 6 functions of the fuel management system, and briefly describe the content of each function. (12 marks)

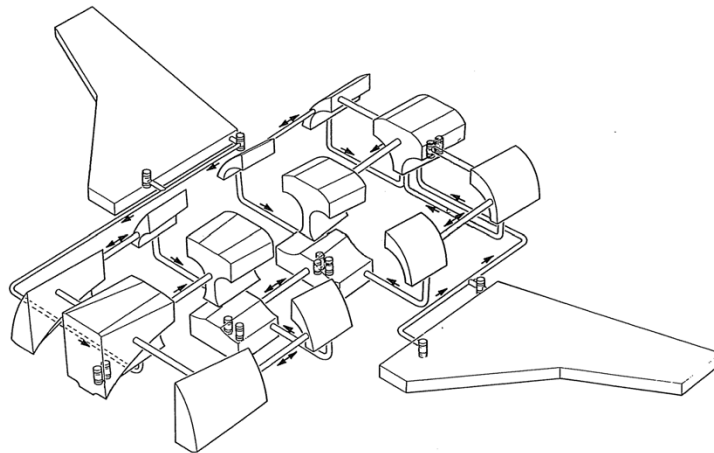

Fig Q4b